

Specification Sheet

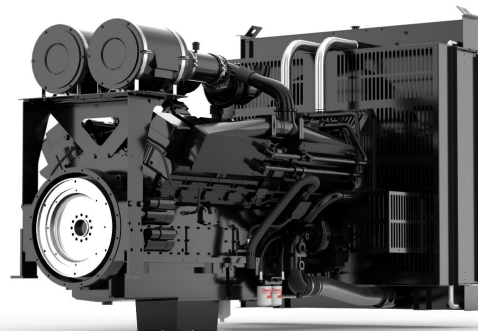

KTA50-G8

Fuel Optimized



Description

The KTA50-Series benefits from years of technical development and improvement to bring customers an innovative and future proof diesel engine that keeps pace with ever changing generator set requirements.

Recognized globally for its performance under even the most severe climatic conditions, the KTA50-Series is widely acknowledged as the most robust and cost-effective diesel engine in its power range for the generator set market.

Features

Coolpac Integrated Design - Products are supplied complete with cooling package and air cleaner kit for a complete power package. Each component has been specifically developed and rigorously tested for G-Drive products, ensuring high performance, durability, and reliability.

Aftercooler – Large capacity integral aftercoolers are supplied with cooling water separate from the engine jacket. This provides cooler, denser intake air for more complete combustion and reduced engine stresses for longer life and low exhaust emissions.

Cooling System – A two pump, two loop system must be employed, i.e. the engine jacket is cooled by one radiator or heat exchanger and the aftercoolers are cooled by a separate radiator or heat exchanger.

Pistons – Pistons are dual Ni-resist, aluminium alloy, ground and shaped to compensate for thermal expansion, which assures a precise fit at all normal operating temperatures.

Service and Support - G-Drive products are backed by an uncompromising level of technical support and after sales service, delivered through a world class service network.

ISO 9001	This product was manufactured in a facility whose quality management system is certified to ISO 9001 and its Health Safety Environmental Management Systems certified to ISO 14001 and ISO 45001.
ISO 14001	
ISO 45001	
RoHS	Consult factory for RoHS information.

1500 rpm (50 Hz Ratings)

Gross engine output			Net engine output			Typical generator set output					
Standby	Prime	Base	Standby	Prime	Base	Standby (ESP)		Prime (PRP)		Base (COP)	
kWm/BHP			kWm/BHP			kWe	kVA	kWe	kVA	kWe	kVA
1429/1915	1200/1608	1100/1475	1388/1861	1174/1574	1074/1440	1340	1675	1133	1416	1036	1295

General Engine Data

Fuel Rating	FR6351
Type	4 cycle, 60-degree Vee, turbocharged, Low-temp aftercooled
Bore mm	159 mm (6.25 in.)
Stroke mm	159 mm (6.25 in.)
Displacement litre	50.3 litre (3067 in. ³)
Cylinder block	16 cylinder
Battery charging alternator	35 amps
Starting voltage	24-volt, negative ground
Fuel system	Cummins PT™ direct injection
Fuel filter	Dual spin-on paper element fuel filters with standard water separator
Lube oil filter type(s)	Spin-on full flow filter
Lube oil capacity (l)	177
Flywheel dimensions	SAE 0

Coolpac Performance Data

Cooling system design	2 pump / 2 loop
Coolant ratio	50% ethylene glycol; 50% water
Coolant capacity (l)	496
Limiting ambient temp.** (°C)	48
Fan power (kWm)	32
Cooling system air flow (m ³ /s)**	28.8
Air cleaner type	Dry replaceable element with restriction indicator

** @ 13 mm H₂O

Fuel Consumption 1500 (50 Hz)

%	kWm	BHP	L/hr	US Gal/hr
Standby Power				
100	1429	1915	345	91.2
Prime Power				
100	1200	1608	289	76.3
75	900	1206	222	58.7
50	600	804	155	40.9
25	300	402	82	21.7
Continuous Power				
100	1100	1475	266	70.4

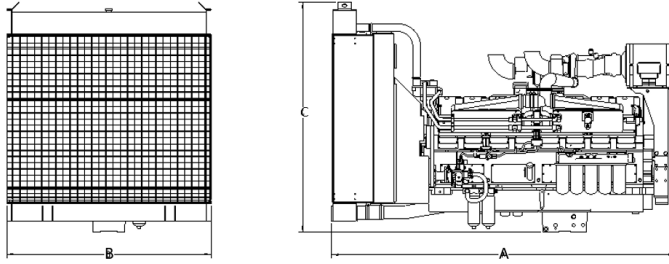

*Drawing for illustration purposes only.

Weights and Dimensions

Length mm	Width mm	Height mm	Weight (dry) kg
3725	2000	2516	6580

Ratings Definitions

Emergency Standby Power (ESP):	Limited-Time Running Power (LTP):	Prime Power (PRP):	Base Load (Continuous) Power (COP):
Applicable for supplying power continuously to varying electrical loads for the duration of power interruption of a reliable utility source. Emergency Standby Power (ESP) is in accordance with ISO 8528 and ISO 3046-1, obtained and corrected in accordance with ISO 15550).	Applicable for supplying power to a constant electrical load for limited hours. Limited-Time Running Power (LTP) is in accordance with ISO 8528.	Applicable for supplying power to varying electrical load for unlimited hours. Prime Power (PRP) is in accordance with ISO 8528. Ten percent overload capability is available in accordance with ISO 3046-1. Data shown above represents gross engine performance and capabilities as per ISO 3046-1, obtained and corrected in accordance with ISO 15550.	Applicable for supplying power continuously to a constant load up to the full output rating for unlimited hours. No sustained overload capability is available for this rating. Consult authorized distributor for rating. (Equivalent to Continuous Power in accordance with ISO 8528 and ISO 3046-1, obtained and corrected in accordance with ISO 15550).