

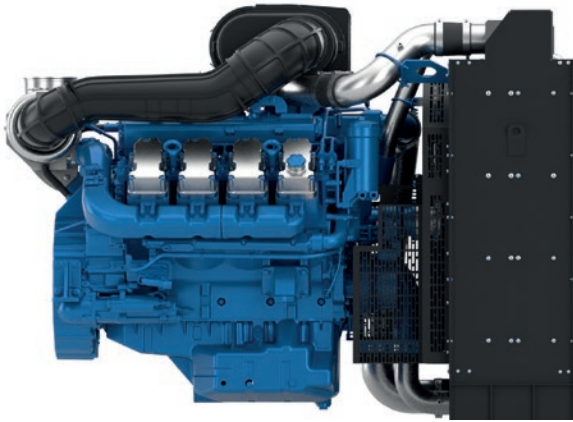

# 8M21

PowerKit ESP/PRP/DCP Diesel Engine



Bore & Stroke (mm)	127 x 165
Displacement (L)	16.72
N° of Cylinders	8
Cylinders Arrangement	In line
Fuel System	Mechanical
Governor (Gov.)	Electronic
Aspiration (Asp.)	Turbocharged & air-to-air cooled

### Customer benefits

Warranty terms - 2 yrs unlimited hours PRP, 4 yrs / 800 ESP  
 50°C Cooling package standard with low derating  
 Extended mean time between overhauls (MTBO)  
 Dual Speed Engine

ESP/PRP/DCP Diesel Engine Models	Gross Engine Output			Typical Generator Output						RPM	Asp.	Gov.
	ESP	PRP	DCP	ESP		PRP		DCP				
	kWm			kWe	kVA	kWe	kVA	kWe	kVA			
8M21G4D0/S	580	530	530	528	660	480	600	480	600	1500	T/A-A	ELEC
8M21G4D0/S	580	530	530	520	650	472	590	472	590	1800	T/A-A	ELEC

\*Please note that models ending with S are switchable 50/60 Hz engines.

## Standard Equipment

Engine and block	Cast iron frame style body structure One-piece forged crankshaft Split-cap forged steel connecting rods Separate cast iron cylinder heads with 4 valves Replaceable dry cylinder liners Aluminum alloy pistons with oil cooling gallery
Cooling System	Radiator and hoses supplied separately Thermostatically-controlled system with belt driven coolant pump and pusher fan High water temperature sensor
Lubrication system	Flat bottom large capacity oil pan Spin-on full-flow lube oil filter Low oil pressure sensor
Fuel system	P type fuel injection pump and injector for higher inject pressure, for engines with electronic governor High pressure Common Rail injection system, for engines with ECU Duplex fine filter and water separation filter assembly with transparent cup for better efficiency
Air intake and exhaust system	Special rear mounted air filter with restriction indicator Exhaust manifold shield for heat isolating
Electrical System	24 Vdc electric starter motor and battery charging alternator
Flywheel and housing	SAE 1 flywheel housing and 14" flywheel

### Dimensions and dry weight (mm/kg)

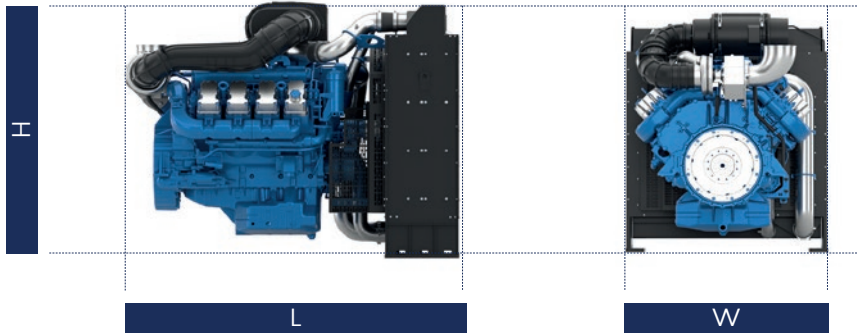

Diesel Engine	Speed RPM	Dimensions and dry weight including radiator			
		L mm	W mm	H mm	WEIGHT Kg
8M21G4D0/S	1500/1800	2062	1345	1618	1819
8M21G4D0/S	1500/1800	2062	1345	1618	1819

## Ratings definitions

### Emergency Standby Power (ESP)

Emergency Standby Power is the maximum power available for a varying load for the duration of a main power network failure. The average load factor over 24 hours of operation should not exceed 70% of the engine's ESP power rating. Typical operational hours of the engine is 200 hours per year, with a maximum usage of 500 hours per year. This includes an annual maximum of 25 hours per year at the ESP power rating. No overload capability is allowed. The engine is not to be used for sustained utility paralleling applications.

### Data Centre Power (DCP)

Data Centre Power is defined as being the maximum power which a generating set is capable of delivering while supplying a variable or continuous electrical load and during unlimited run hours. Depending on the sites to supply and the availability of reliable utility, the generating set manufacturer is responsible to define what power level he is able to supply to fulfil that requirement including hardware or software or maintenance plan adaptation.

### Prime Rated Power (PRP)

Prime Power is the maximum power available for unlimited hours of usage in a variable load application. The average load factor should not exceed 70% of the engine's PRP power rating during any 24 hour period. An overload capability of 10% is available, however, this is limited to 1 hour within every 12 hour period.

- 1) All ratings are based on operating conditions under ISO 8528-1, ISO 3046, DIN6271. Performance tolerance of  $\pm 5\%$ .
- 2) Test conditions: 100 kPa, 25°C air inlet temperature, relative humidity of 30%, with fuel density 0.84 kg/L. Derating may be required for conditions outside these; please contact the factory for details.

